

Marshmallow Challenge

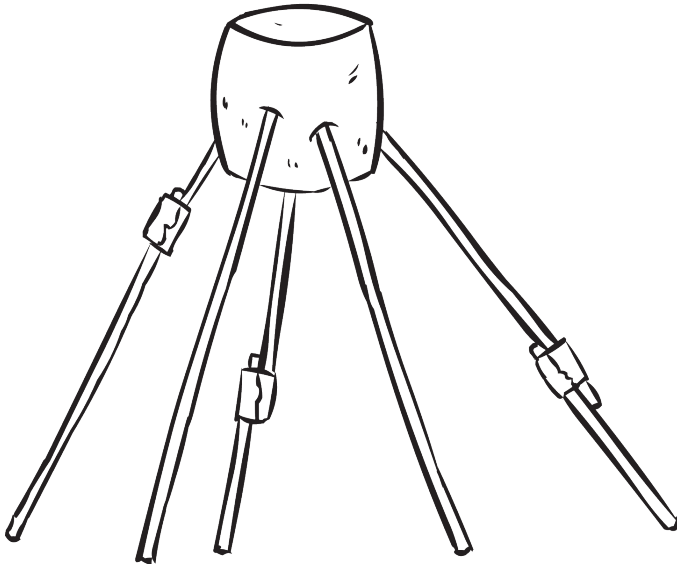

At A Glance

Classic problem-solving exercise for small teams.

Benefits

- Playful & fun
- Simple props
- Promotes creativity
- Builds problem-solving skills
- Many metaphors

Time 20 - 30 min

Props

- Bag of spaghetti
- Roll of string/twine
- Masking-tape
- Marshmallows
- Measuring tape

People Small 8 -15

How To Play

1. In advance, prepare one kit containing the following items for each small group:
 - 20 sticks of spaghetti
 - 1 metre (3?) of string
 - 1 metre (3?) of masking tape
 - 1 x marshmallow
2. Gather your group and divide them into small teams of approx 4 to 8 people.
3. Distribute one kit to each small group.
4. Instruct the groups to use (only) the contents of the kits to build the tallest free-standing structure, and to place the marshmallow on top (highest peak of structure.)
5. Explain that every group has exactly 20 minutes to complete the task.
6. Groups are permitted to use as little or all of their resources and break the spaghetti, string and tape as they choose.
7. The team with the tallest (free-standing) structure supporting the highest marshmallow at the end of the time, wins.

Variations

- **Limited Resources:** Vary any one or more of the items in the kit, such as more or fewer spaghetti sticks, tape or string.
- **Marshmallows Plus:** Supply ten or more marshmallows, allowing each group to use marshmallows to form part of their structure. Yet, as in the original challenge, a marshmallow must be positioned on top of the structure.
- **Food Drop:** Take a look at the classic group initiative the Great Egg Drop for a similar limited-resources and food-based exercise.

Leadership Tips, Video Tutorials & More

<https://www.playmeo.com/activities/team-building-problem-solving-activities/marshmallow-challenge/>